

## **Modelling Quartz Crystals**

This document explains how a Quartz Crystal can be modelled using a series RLC circuit and a parallel (package) Capacitor. Please note that Crystal Oscillators are available in the XTAL.OLB Library under the SPB/OrCAD Installation.

# Equivalent Electrical Model

Crystal oscillators can be modelled as a series RLC circuit along with a parallel capacitor as shown in Figure 1. Quartz crystal oscillators tend to operate towards their “series resonance”.

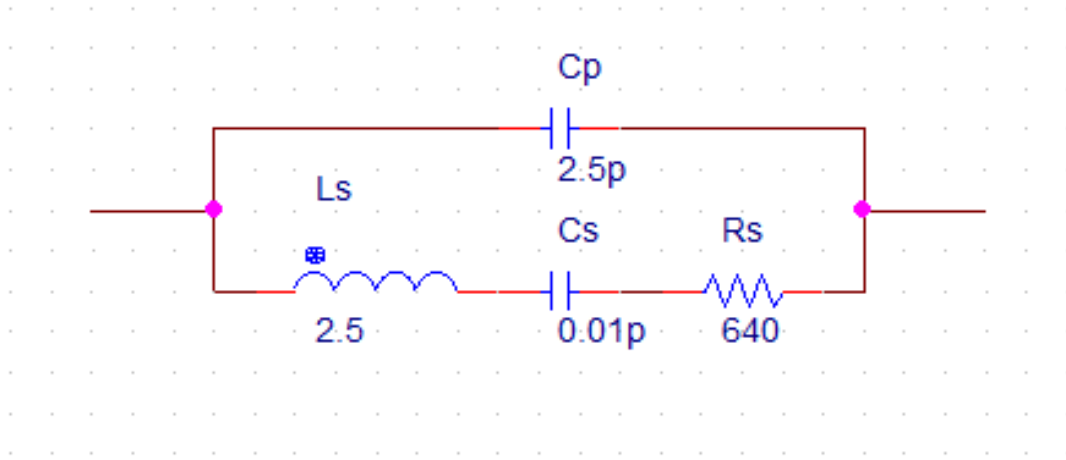

Figure 1: Equivalent Electrical Model

The equivalent impedance of the crystal has a series resonance where Cs resonates with inductance, Ls at the crystals operating frequency. This frequency is called the crystals series frequency,  $f_s$ . As well as this series frequency, there is a second frequency point established as a result of the parallel resonance created when Ls and Cs resonates with the parallel capacitor Cp as described below:

## Crystal Impedance against Frequency

$$R = R \text{ and } X_{LS} = 2\pi f L_s$$

$$X_{CS} = 1/2\pi f C_s \text{ and } X_{CP} = 1/2\pi f C_p$$

$$Z = \frac{\sqrt{R_s^2 (X_{LS}^2 - X_{CS}^2)^2} * X_{CS}}{\sqrt{R_s^2 (X_{LS}^2 - X_{CS}^2)^2 + X_{CS}^2}} = \frac{1}{1 + 2\pi C_p \sqrt{R_s^2 (X_{LS}^2 - X_{CS}^2)^2}}$$

## Crystal Reactance against Frequency

$$X_S = R^2 + (X_{LS} - X_{CS})^2$$

$$X_{CP} = 1/(2\pi f C_p) \text{ and } X_P = (X_S * X_{CP}) / (X_S + X_{CP})$$

## Series Resonant Frequency

$$f_s = 1/(2\pi\sqrt{L_s C_s})$$

## Parallel Resonant Frequency

$$f_p = 1/2\pi\sqrt{L_s (C_p * C_s)/(C_p + C_s)}$$

## Crystal Oscillators Q-factor

$$Q = X_L/R = 2\pi fL/R$$

If this Q-factor value is high, it contributes to a greater frequency stability of the crystal at its operating frequency making it ideal to construct crystal oscillator circuits.

A Crystal has an extremely high Q-Factor (Quality Factor) of 5000 or more, which leads to very long simulation time for any oscillation to build up.

It is possible that due to numerical range initial amplitude build up may not get propagated to next simulation cycle and the oscillation build up is not visible.

A pulse is injected in the Crystal circuit or Initial Condition specified on Capacitors to accelerate the amplitude build up and speed up simulation.

## Simulation results

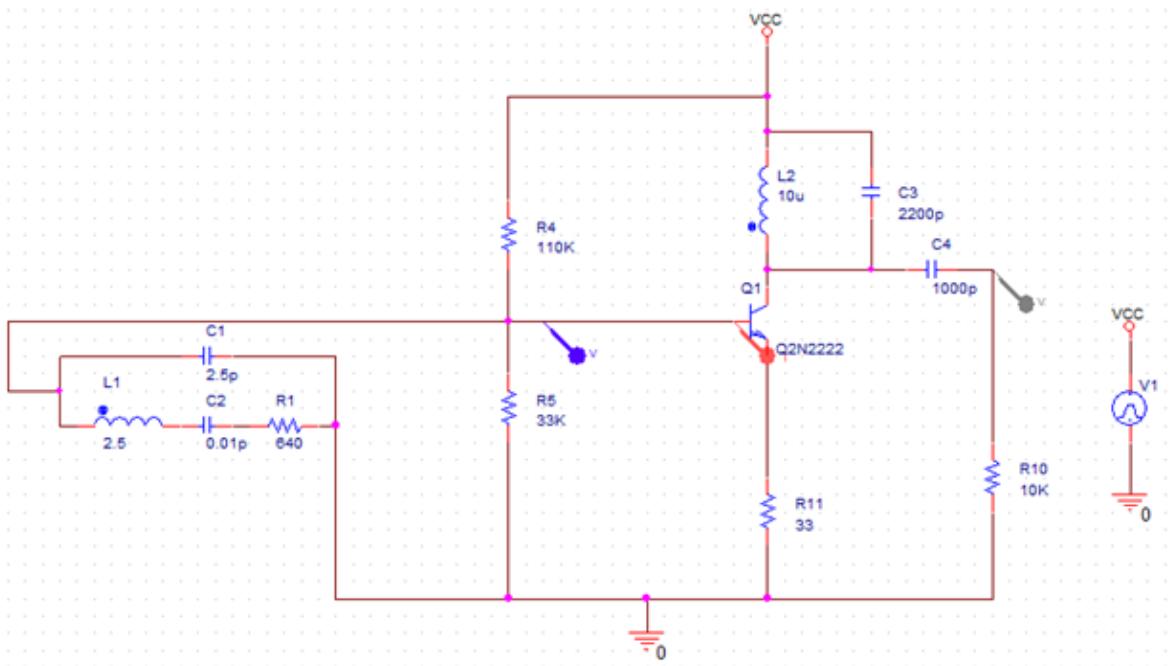

Figure 2: Circuit diagram

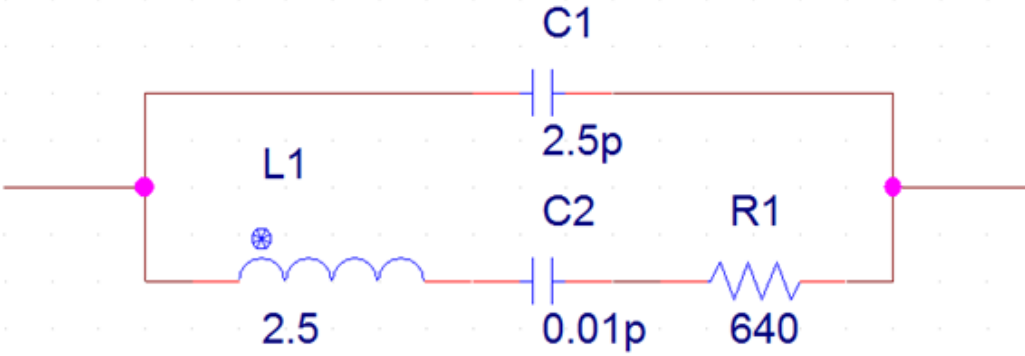

Figure 3: Equivalent Circuit (Model) Parameters

$L1 = 2.5, C2 = 0.01\text{pF}, R1 = 640\Omega, C1 = 2.5\text{pF}$

**Series Resonant Frequency**

$$f_s = 1/2\pi\sqrt{L_s C_s} = 1/2\pi\sqrt{2.5*0.01\text{p}} = 1.0065\text{MHz}$$

**Parallel Resonant Frequency**

$$f_p = 1/2\pi\sqrt{L_s (C_p * C_s)/(C_p+C_s)} = 1/2\pi\sqrt{2.5(2.5\text{p}*0.01\text{p})/(2.5\text{p}+0.01\text{p})} = 1.0085\text{MHz}$$

**Crystal Oscillators Q-factor**

$$Q = X_L/R = 2\pi fL/R = (2\pi*10^6*2.5)/640 = 0.0245436*10^6 = 24543 \approx 25000$$

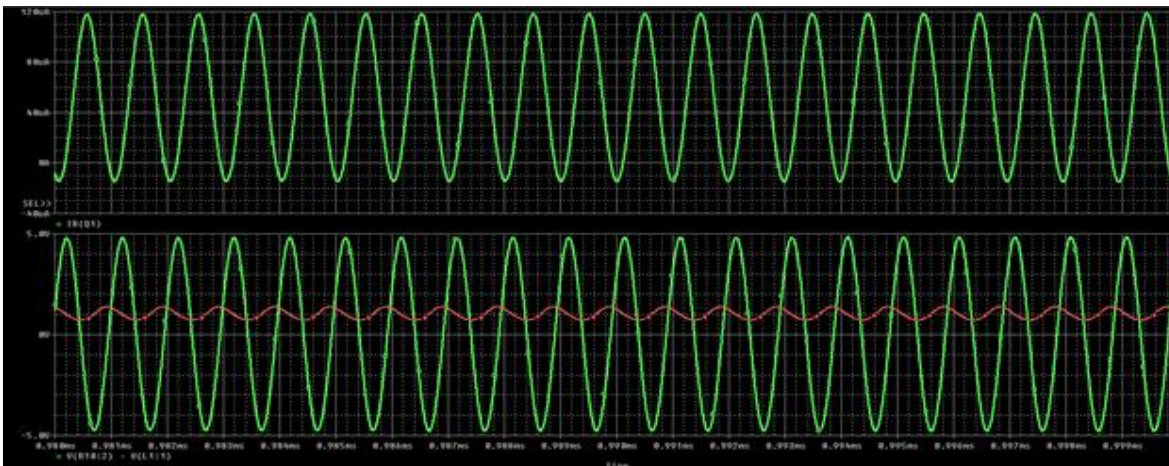

Figure 4: Simulation Results